

12.6 Dimensions of Servo Motors (ECMA Series)

Motor Frame Size: 80mm and below Models

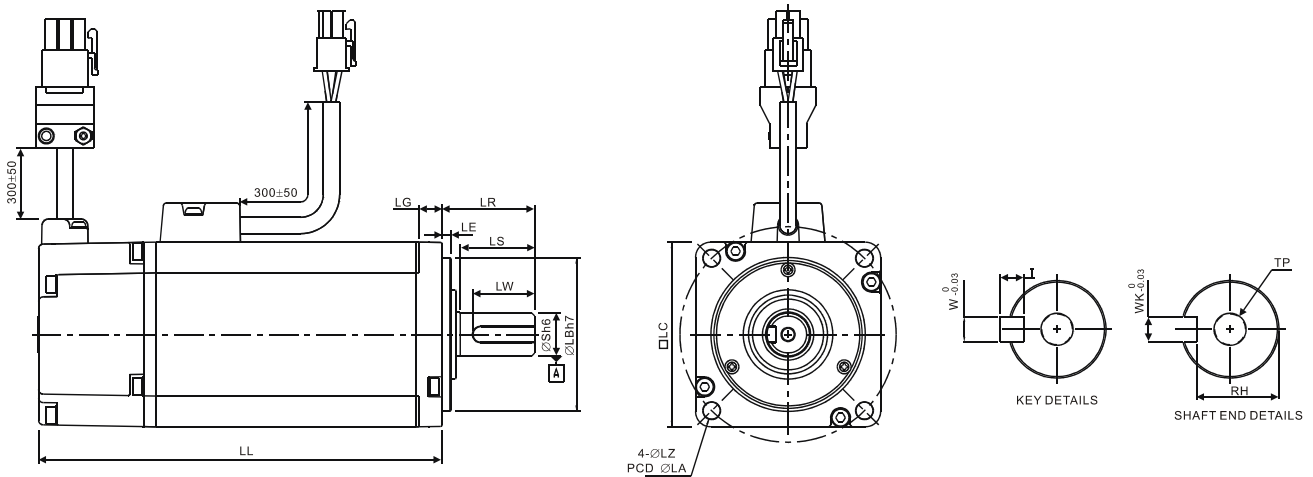

Model	C10401□S	C10602□S	C10604□S	C10804□S	C10807□S
LC	40	60	60	80	80
LZ	4.5	5.5	5.5	6.6	6.6
LA	46	70	70	90	90
S	8 ^(+0/-0.009)	14 ^(+0/-0.011)	14 ^(+0/-0.011)	14 ^(+0/-0.011)	19 ^(+0/-0.013)
LB	30 ^(+0/-0.021)	50 ^(+0/-0.025)	50 ^(+0/-0.025)	70 ^(+0/-0.030)	70 ^(+0/-0.030)
LL (without brake)	100.6	105.5	130.7	112.3	138.3
LL (with brake)	136.6	141.6	166.8	152.8	178
LS (without oil seal)	20	27	27	27	32
LS (with oil seal)	20	24	24	24.5	29.5
LR	25	30	30	30	35
LE	2.5	3	3	3	3
LG	5	7.5	7.5	8	8
LW	16	20	20	20	25
RH	6.2	11	11	11	15.5
WK	3	5	5	5	6
W	3	5	5	5	6
T	3	5	5	5	6
TP	M3 Depth 8	M4 Depth 15	M4 Depth 15	M4 Depth 15	M6 Depth 20

NOTE

- 1) Dimensions are in millimeters. Weights are in kilograms (kg) and (pounds (lbs)).
- 2) Dimensions and weights of the servo motor may be revised without prior notice.
- 3) The boxes (□) in the model names are for optional configurations. (Please refer to section 1.2 for model explanation.)
- 4) Actual measured values are in metric units. Dimensions and weights in (imperial units) are for reference only.